



OWNER'S MANUAL

AMX-100/AMX-100FX
COMPACT MIXER WITH DIGITAL EFFECT



www.altoproaudio.com
Version 2.0 NOV. 2007

English

IMPORTANT SAFETY INSTRUCTION



TO REDUCE THE RISK OF ELECTRIC SHOCK PLEASE DO NOT REMOVE THE COVER OR THE BACK PANEL OF THIS EQUIPMENT. THERE ARE NO PARTS NEEDED BY USER INSIDE THE EQUIPMENT. FOR SERVICE, PLEASE CONTACT QUALIFIED SERVICE CENTERS.

 This symbol, wherever used, alerts you to the presence of un-insulated and dangerous voltages within the product enclosure. These are voltages that may be sufficient to constitute the risk of electric shock or death.

 This symbol, wherever used, alerts you to important operating and maintenance instructions. Please read.

- ⊕ Protective Ground Terminal
- ~ AC mains (Alternating Current)
- ⚡ Hazardous Live Terminal

ON: Denotes the product is turned on.
OFF: Denotes the product is turned off.

CAUTION

Describes precautions that should be observed to prevent damage to the product.

1. Read this Manual carefully before operation.
2. Keep this Manual in a safe place.
3. Be aware of all warnings reported with this symbol. 
4. Keep this Equipment away from water and moisture.
5. Clean it only with dry cloth. Do not use solvent or other chemicals.
6. Do not damp or cover any cooling opening. Install the equipment only in accordance with the Manufacturer's instructions.
7. Power Cords are designed for your safety. Do not remove Ground connections! If the plug does not fit your AC outlet, seek advice from a qualified electrician. Protect the power cord and plug from any physical stress to avoid risk of electric shock. Do not place heavy objects on the power cord. This could cause electric shock or fire.
8. Unplug this equipment when unused for long periods of time or during a storm.
9. Refer all service to qualified service personnel only. Do not perform any servicing other than those instructions contained within the User's Manual.
10. To prevent fire and damage to the product, use only the recommended fuse type as indicated in this manual. Do not short-circuit the fuse holder. Before replacing the fuse, make sure that the product is OFF and disconnected from the AC outlet.

WARNING

To reduce the risk of electric shock and fire, do not expose this equipment to moisture or rain.



Dispose of this product should not be placed in municipal waste and should be separate collection.

11. Move this Equipment only with a cart, stand, tripod, or bracket, specified by the manufacturer, or sold with the Equipment. When a cart is used, use caution when moving the cart / equipment combination to avoid possible injury from tip-over. 

12. Permanent hearing loss may be caused by exposure to \ extremely high noise levels. The US. Government's Occupational Safety and Health Administration (OSHA) has specified the permissible exposure to noise level. These are shown in the following chart:

HOURS X DAY SPL EXAMPLE

8	90	Small gig
6	92	train
4	95	Subway train
3	97	High level desktop monitors
2	100	Classic music concert
1,5	102	
1	105	
0,5	110	
0,25 or less	115	Rock concert

According to OSHA, an exposure to high SPL in excess of these limits may result in the loss of heat. To avoid the potential damage of heat, it is recommended that Personnel exposed to equipment capable of generating high SPL use hearing protection while such equipment is under operation.

The apparatus shall be connected to a mains socket outlet with a protective earthing connection.

The mains plug or an appliance coupler is used as the disconnect device, the disconnect device shall remain readily operable.

IN THIS MANUAL:

1. INTRODUCTION.....	1
2. FEATURES.....	2
3. READY TO START ?.....	4
4. CONTROL ELEMENTS.....	5
5. INSTALLATION AND CONNECTION.....	11
6. FOR THE EXPERTS WHO WANT TO KNOW MORE.....	12
7. PRESET LIST.....	13
8. BLOCK DIAGRAMS.....	14
9. TECHNICAL SPECIFICATION.....	15
10. WARRANTY	16

1. INTRODUCTION

Thank you for your purchasing the ▲LTO AMX-100(FX) compact mixer with digital multieffect. It is just one of the many ▲LTO products that a talented, multinational Team of Audio Engineers and Musicians have developed with their great passion for music. Your AMX-100(FX) it is a remarkable compact mixing desk that doesn't find many equals in the market today. With enough microphone and Line-level inputs for serious, small live performances, your AMX-100(FX) also includes a 24 Bit digital multieffect with 16 Factory Presets and 16 variations for every preset, for a total of 256 different digital effects. There is a three bands EQ on all input channels and separate Main Mix and Control Room outputs for Multi-zone operation with different volume settings. The 2TK input usually used for Tape of CD sources even comes with its own volume control and this feature is hard to find in a mixer of this size. Use it for small Gigs, for Computer Audio. AMX-100(FX) also is a flexible tool for your Multimedia presentations.

Enjoy your AMX-100(FX) and make sure to read this Manual carefully before operation!

2. FEATURES

The AMX-100 and AMX-100FX share the following features:

- ▲ 2 MIC input channels with gold plated XLRs and balanced Line input.
- ▲ 4 stereo input channels with balanced TRS jacks.
- ▲ Ultra-low noise discrete MIC pre-amps with +48V Phantom power.
- ▲ Extremely high headroom offering extra dynamic range.
- ▲ Balanced inputs for highest signal integrity and low-noise operation.
- ▲ Warm, natural 3-band EQ on each channel.
- ▲ AUX send switch-able to PRE/POST fader.
- ▲ 2 AUX returns for additional functionality.
- ▲ Peak LED on each channel.
- ▲ 2-Track inputs with level control assignable to main mix, control room / headphone outputs.
- ▲ Highly accurate 4-segment bar graph meters.

Additionally, the AMX-100FX is also equipped with following features:

- ▲ 24 bit digital effects processor with 256 effects (16 presets 16 variations).
- ▲ Effect on/off with MUTE switch or an optional footswitch.

<p>MIC 1</p> <p>MIC 2</p>		<p>PHONES</p>		<p>MAIN MIX OUTPUT</p> <p>LEFT</p> <p>RIGHT</p>		<p>2-TRACK IN/OUT</p> <p>L</p> <p>R</p> <p>TAPE IN</p> <p>TAPE OUT</p>		<p>ALTO[®]</p> <p>AMA[™] -100 FX</p> <p>10-CHANNEL MIXING CONSOLE WITH DIGITAL EFFECTS</p>	
<p>BAL OR UNBAL</p> <p>LINE IN 1</p>		<p>BAL OR UNBAL</p> <p>LINE IN 2</p>		<p>AUX SENDS</p>		<p>STEREO AUX RETURNS</p> <p>LEFT</p> <p>RIGHT</p>		<p>CTRL ROOM OUTPUT</p> <p>LEFT</p> <p>RIGHT</p>	
<p>TRIM</p> <p>+15dB -30dB LINE 0dB 44dB MIC</p>		<p>TRIM</p> <p>+15dB -30dB LINE 0dB 44dB MIC</p>		<p>LINE IN 3/4</p> <p>LEFT (MONO)</p> <p>RIGHT</p>		<p>LINE IN 5/6</p> <p>LEFT (MONO)</p> <p>RIGHT</p>		<p>DSP FOOTSWITCH</p>	

<p>EQ</p> <p>HI 12kHz</p> <p>-15 +15</p>		<p>EQ</p> <p>HI 12kHz</p> <p>-15 +15</p>		<p>27K IN</p> <p>MAX</p>		<p>27K TO CTRL ROOM</p>		<p>EQ</p> <p>HI 12kHz</p> <p>-15 +15</p>		<p>EQ</p> <p>HI 12kHz</p> <p>-15 +15</p>		<p>16 1 2 3 4 5 6 7 8 9 10 11 12</p> <p>PRESETS</p>	
<p>EQ</p> <p>MID 2.5kHz</p> <p>-12 0 +12</p>		<p>EQ</p> <p>MID 2.5kHz</p> <p>-12 0 +12</p>		<p>AUX RTN (DPX)</p> <p>-∞ +15</p>		<p>27K TO MIX</p> <p>TAPE</p>		<p>EQ</p> <p>MID 2.5kHz</p> <p>-12 +12</p>		<p>EQ</p> <p>MID 2.5kHz</p> <p>-12 +12</p>		<p>16 1 2</p> <p>VARIATIONS</p>	
<p>EQ</p> <p>LOW 80Hz</p> <p>-15 +15</p>		<p>EQ</p> <p>LOW 80Hz</p> <p>-15 +15</p>		<p>AUX SENDS</p> <p>-∞ +15</p>		<p>PHONES CTRL ROOM</p> <p>MAX</p>		<p>EQ</p> <p>LOW 80Hz</p> <p>-15 +15</p>		<p>EQ</p> <p>LOW 80Hz</p> <p>-15 +15</p>		<p>12 11 10 9 8 7</p> <p>PEAK</p>	
<p>AUX</p> <p>POST (PRE)</p> <p>-∞ +15</p>		<p>AUX</p> <p>POST (PRE)</p> <p>-∞ +15</p>		<p>OUTPUT LEVEL</p> <p>L</p> <p>-20 0 +5 CLIP PH</p>		<p>R</p> <p>0 +5 CLIP PH</p>		<p>AUX</p> <p>POST (PRE)</p> <p>-∞ +15</p>		<p>AUX</p> <p>POST (PRE)</p> <p>-∞ +15</p>		<p>PEAK</p> <p>DFX MUTE</p>	
<p>PAN</p> <p>LEFT RIGHT</p>		<p>PAN</p> <p>LEFT RIGHT</p>		<p>MAIN MIX LEVEL</p> <p>-∞ 0 +15</p>		<p>BAL</p> <p>LEFT RIGHT</p>		<p>BAL</p> <p>LEFT RIGHT</p>		<p>LEVEL</p> <p>LEVEL</p> <p>-∞ +15</p>		<p>1. VOCAL 1</p> <p>2. VOCAL 2</p> <p>3. LARGE HALL</p> <p>4. SMALL HALL</p> <p>5. LARGE ROOM</p> <p>6. SMALL ROOM</p> <p>7. PLATE</p> <p>8. TAPE REVERB</p> <p>9. SPRING REVERB</p> <p>10. MONO DELAY</p> <p>11. STEREO DELAY</p> <p>12. FLANGER</p> <p>13. CHORUS</p> <p>14. REV. + DELAY</p> <p>15. REV. + FLANGER</p> <p>16. REV. + CHORUS</p>	
<p>LEVEL</p> <p>LEVEL</p> <p>-∞ +15</p>		<p>LEVEL</p> <p>LEVEL</p> <p>-∞ +15</p>		<p>3/4</p>		<p>5/6</p>		<p>LEVEL</p> <p>LEVEL</p> <p>-∞ +15</p>		<p>LEVEL</p> <p>LEVEL</p> <p>-∞ +15</p>			

AMA[™] -100 **FX**



SMALL GIG HOOKUP DIAGRAM

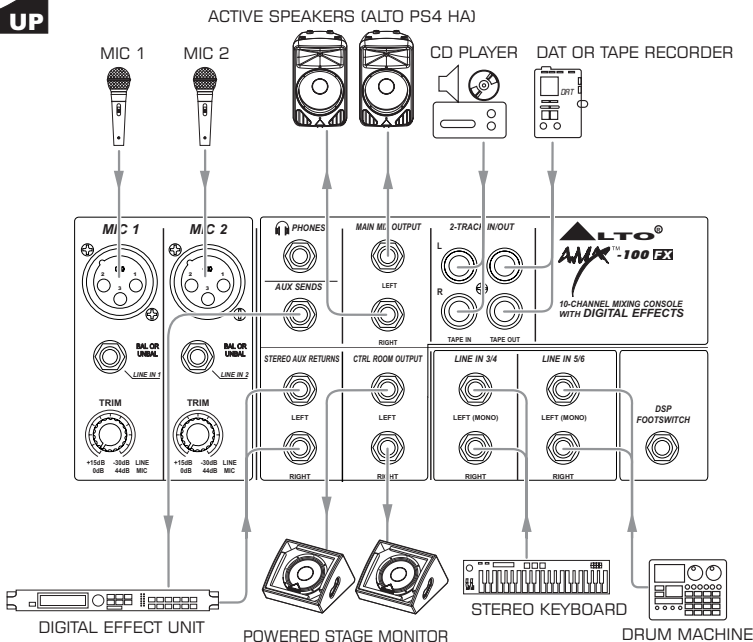

COMPUTER SET-UP DIAGRAM

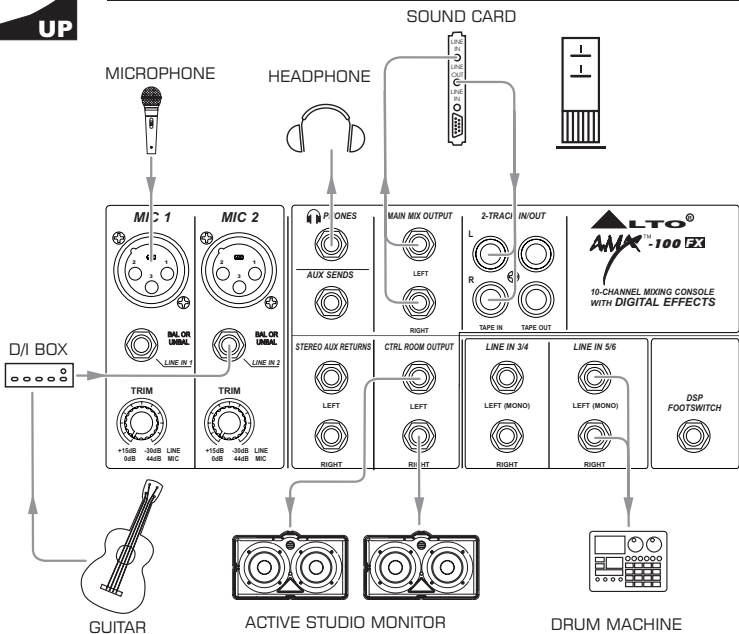

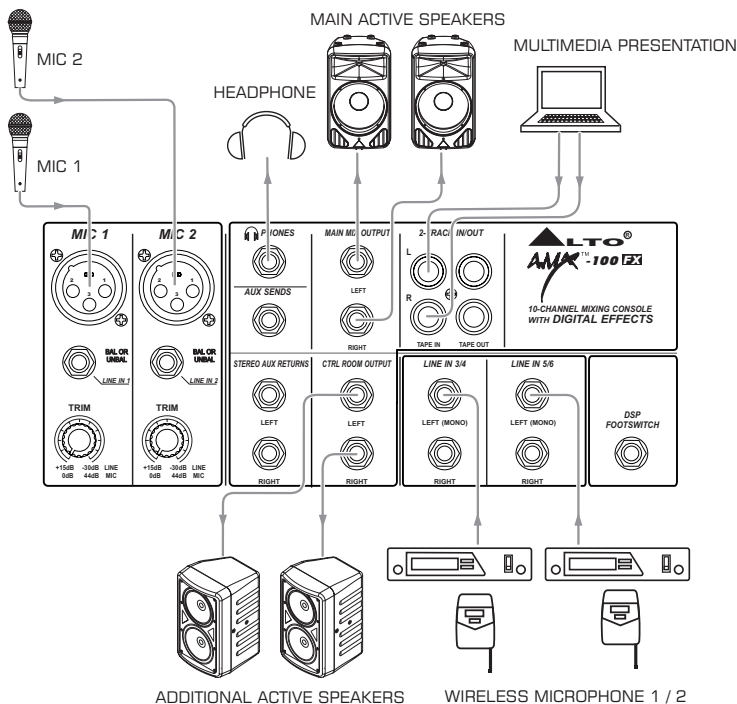

3. READY TO START?

- a. Please check the AC voltage available in your country before connecting your AMX-100(FX) to the AC socket.
- b. Be sure that the main power switch is turned off before connecting your AMX-100(FX) to the AC socket.
Also, you should make sure that all level controls are turned down, This will avoid damages to your speakers and also avoid excessive noise.
- c. Before disconnecting your AMX-100(FX) please turn-off the power switch first.
- d. Do not use solvent to clean your AMX-100(FX) using dry and clean cloth will be fine.
- e. Before turning on your AMX-100(FX), you shall connect it to a power amplifier and turn-on the AMX-100(FX) BEFORE the power amplifier. Once you have finished your working session, you shall turn the mixer off AFTER the power amplifier.

4. CONTROL ELEMENTS

1 MONO MIC/LINE CHANNELS

Your AMX-100(FX) is equipped with 2 low-noise microphone preamplifiers with optional phantom power, 44dB of Gain and over 100dB of S/N ratio. You can connect almost any type of microphone. Dynamic microphones do not need phantom power. Use phantom power only with condenser microphones but make sure that the phantom power button is disengaged before connecting the microphone. Phantom power will not damage your dynamic microphones but it may damage tube or ribbon microphones, so make sure to read the microphone instructions manual before engage phantom power.

Use button (2) to activate/deactivate phantom power. These two channels are also equipped with 1/4" TRS balanced/unbalanced plugs to connect line-level instruments such as keyboards, drum machines and effect devices.

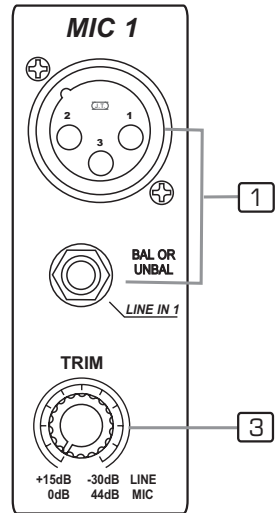

⚠NOTE: Never try to connect a line-level signal to the XLR MIC input when the phantom power is engaged, or you may seriously damage your equipment.

2 PHANTOM

This switch will apply +48 Volt Phantom Power only to the 2 XLR microphone inputs. Never connect microphones when the phantom power is already ON .

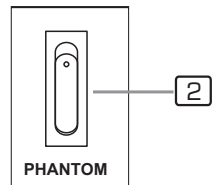

3 TRIM

This control is provided with 2 different indication rings: one is for the MIC and the other for the LINE input.

When you use a Microphone, you shall read the OUTSIDE ring (0~44dB); when you use a line level instrument, you shall read the INSIDE ring (+15~30dB). For optimum operation, you shall set this control in a way that the PEAK LED will light up only occasionally in order to avoid distortion on the input channel.

4 STEREO INPUTS

These are channels 3/4 and 5/6. They are organised in stereo pair and provided with 1/4" TRS phone sockets. If you connect only the LEFT jack, the input will operate in mono mode. You can use these inputs with a stereo keyboard, drum machine, etc.

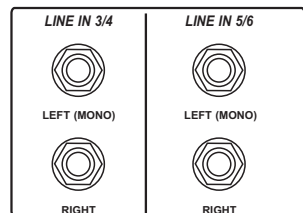

4



4. CONTROL ELEMENTS

EQUALIZATION

You have three EQ control for each mono and stereo input channel each providing +/-15dB of boost and cut (-MID is +/-12dB). The signal will be unaffected when the controls are on center position. You may use an external equalizer to make up a mix properly but a master equalizer will not have effect on a single channel and you may overload the signal easily. Individual EQ will give you a much better control on single tracks.

5 HI

If you turn this control up, you will boost all the frequencies above 12kHz (shelving filter). You will add transparency to vocals and guitar, and also make cymbals crispier. Turn the control down to cut all frequencies above 12 kHz. In such way, you can reduce sibilances of human voice or reduce the hiss of a Tape player.

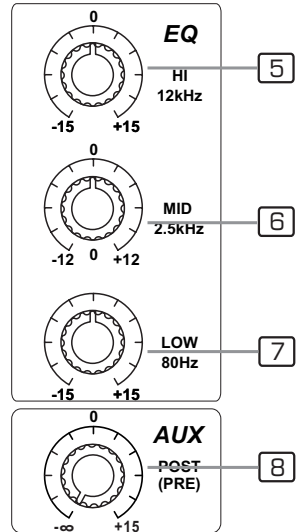

6 MID

This is a peaking filter and it will boost/cut frequencies with their center at 2.5kHz. This control will affect especially upper male and lower female vocal ranges and also the harmonics of most musical instruments.

7 LOW

If you turn this control up, you will boost all frequencies below 80Hz. You will give more punch to bass drums and bass guitar; and you will make the male vocalist more "macho". Turn it down and you will cut all the frequencies below 80Hz. In this Way, you can avoid low-frequency vibrations and resonance thus preserving the life of your woofers.

8 AUX

This control is used to adjust the level of respective channel signal sent to the Auxiliary Bus. The configuration is post-fader so the signal sent to the AUX Bus will be affected by the LEVEL control of that particular channel. In this typical compact unit, the channel signal is not only assigned to external effect or processor equipment directly but also to internal digital multi-effect.

✖**NOTE:** There is the possibility to configure this AUX control as Pre-fader as we will explain later in this manual.



4. CONTROL ELEMENTS

9 PAN

This is the PANORAMA control, or balance control. You can adjust the stereo image of the signal via this control. Keep this control in center position and your signal will be positioned in the middle of stage. Turn this control fully counter clockwise and the signal will be present only on the left speaker and vice-versa. Of course a large number of intermediate positions is available.

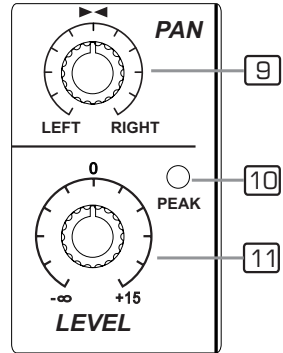

10 PEAK LED

This red LED will let you know about the status of the signals getting into your AMX-100(FX). Connect a microphone or an instrument to your AMX-100(FX) and sing/play at normal volume. Set the LEVEL control of that channel so that the PEAK LED lights-up only occasionally. If this LED is always on, you will experience a lot of distortion and you should turn the level control down. If this LED never light up, turn the level control up again.

11 LEVEL

This is the Master control for the channel signal. You must position the GAIN control correctly first (so that the PEAK LED only flashes occasionally) and the LEVEL control in between 0dB and 3 o'clock. If you have to turn up the level control too much, your GAIN control is probably set too low. If the level control is turned down too much, your GAIN is probably too high and your signal is heavily distorted.

MASTER SECTION

12 MAIN MIX LEVEL

This control sets the amount of signal simultaneously sent to the MAIN MIX OUTPUT and TAPE OUT.

13 LED METER

These left and right meters have 4 LEDs each with range of -20 dB to +18 dB(CLIP). The 0 LED corresponds to a level output of 0 dBu. The CLIP LEDs come to life when the output reaches +18 dBu. Set the MAIN MIX level control so that the CLIP LEDs only flash occasionally. In general, you get a good mix level when the Meter LEDs operate in the range 0 to +5. If you exceed +5, you will get distortion. If even -20 LEDs are sleeping, your signal-to-noise ratio will suffer.

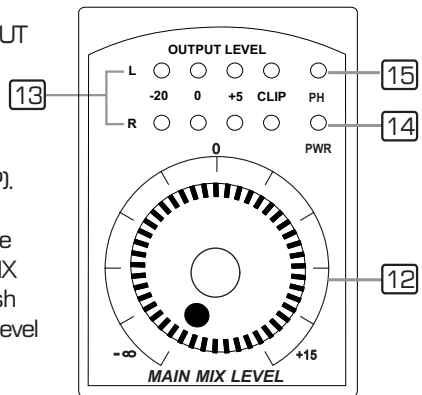



4. CONTROL ELEMENTS

14 POWER LED

This LED indicated when your AMX-100(FX) switched-on.

15 PH LED

This LED indicates when the PHANTOM POWER is engaged.

16-17 2-TRACK signal path

If you push down the 2TK TO CONTROL ROOM button, the 2 TRACK IN signal will be routed into the CONTROL ROOM OUTPUT and the level will be adjusted by the PHONES/CONTROL ROOM knob. If you push down the 2TK TO MIX button, the 2 TRACK IN signal will be routed into the MAIN MIX OUTPUT and will be adjusted by the MAIN MIX LEVEL control.

✖NOTE: You can push down these two buttons simultaneously, the 2 TRACK IN signal will be routed into both CONTROL ROOM OUTPUT and MAIN MIX OUTPUT, and the level of two output signals will be adjusted by respective control knobs.

18 2TK IN

This control is used to adjust the level of 2TK IN, which can be varied from $-\infty$ to MAX.

19 AUX RETURN

This control is used to adjust the level of the return stereo signal coming from external / internal multieffect effect. The signal of the AUX RETURN will be sent to MAIN MIX OUTPUT.

20 MASTER AUX SEND

This knob will provide overall control for the AUX send level before it is delivered to the AUX SEND OUTPUT. It ranges from off when the knob is turned down completely, to unit gain with the knob in center position, to +15dB when turned up fully.

21 PHONES/CONTROL ROOM

This control sets the amount of signal simultaneously sent to the CONTROL ROOM OUTPUT and PHONES.

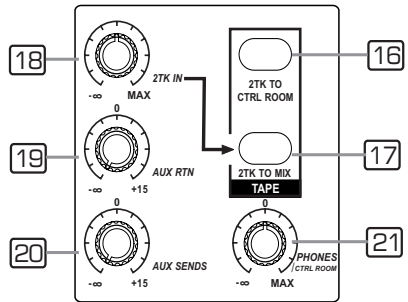



4. CONTROL ELEMENTS

INPUT/OUTPUT CONNECTORS

22 TAPE IN

Use the Tape input to connect a CD Player, Tape, DAT, iPod or any other line-level source. You can send this signal either to CONTROL ROOM OUTPUT and / or to the MAIN MIX OUTPUT using the relative 2TK TO select buttons.

TAPE OUT

These RCA jacks will route the main mix signal into a tape or DAT recorder:

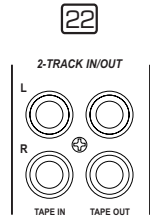

23 PHONES

This socket will be used to send the signal to a headphone.

24 AUX SENDS

This 1/4" phone socket is used to send out the signal from the AUX Bus of the input channels into external devices such as effect units and / or stage monitors.

25 STEREO AUX RETURNS

You can use these stereo 1/4" phone sockets to return the stereo signal of an effect unit to the MAIN MIX. Alternatively you can use them as an extra auxiliary input using the AUX RETURN level control as volume control.

26 CONTROL ROOM OUTPUT

These 1/4" phone sockets will be used to send the signal to a pair of powered Studio Monitor speakers or to a second set of PA.

27 MAIN MIX OUTPUT

This stereo output is controlled by the MAIN MIX LEVEL and will send the audio signal to an external amplifier. The output level can be varied from $-\infty$ to +10 dB.

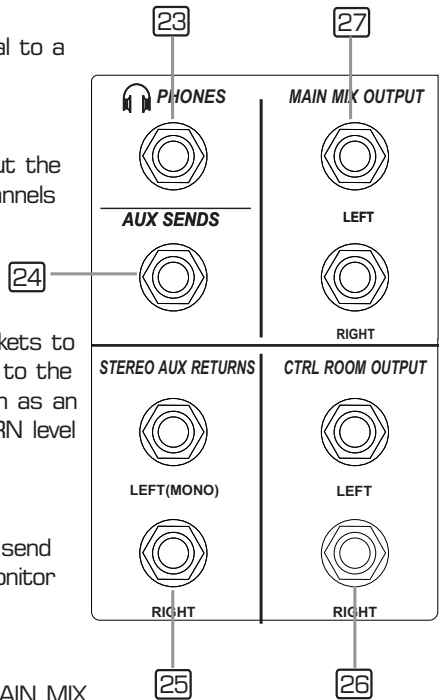



4. CONTROL ELEMENTS

BIT DIGITAL MULTIEFFECT

This section regards only AMX-100FX

28 PRESETS CONTROL

This knob will select one of the 16 Factory Presets. These include several different reverbs, chorus, flanger; delay and combinations of the above.

29 VARIATIONS CONTROL

For each of the 16 Factory Presets you can apply up to 16 variations, so in total your AMX-100FX offers 256 different presets. If you want to know which Parameter is modified by this control, please look at Section 7. of this manual.

30 DFX MUTE BUTTON

This button is used to activate / deactivate the digital multieffect. Alternatively, you can also use the DFX FOOTSWITCH for a faster operation.

31 PEAK LED

This LED will flash when the signal input into the digital multieffect is too strong. When the digital effect module is muted by the (30) button the LED also lights up.

32 DSP FOOTSWITCH SOCKET

This 1/4" phone jack can be used to connect an external optional footswitch to turn on /off the onboard digital multieffect.

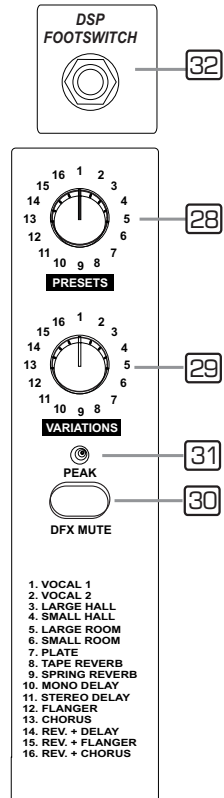

REAR PANEL

33 POWER

This switch is used to turn the main power ON and OFF.

34 18VAC

This connector is used to connect the supplied AC Adapter.

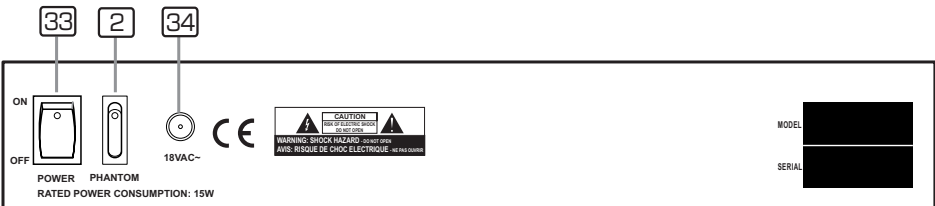



5. QUICK START AND CONNECTIONS

OK, you have got to this point and you are now in the position to successfully operate your AMX-100(FX). However, we advise you to read carefully the following section to get the best out of your AMX-100(FX).

Not paying enough attention to the input signal level, to the routing of the signal and the assignment of the signal will result in unwanted distortion, a corrupted signal or no sound at all. So you should follow these procedures before operation:

1. Before connecting microphones or instruments, make sure that the power of all your systems components including the AMX-100(FX) is turned off. Also, make sure that all input and output controls are turned down. This will avoid damage to your speakers and excessive noise.
2. Properly connect all external equipment such as microphone, power amplifier, speakers etc.
3. Now, turn on the power of any peripheral devices, then connect the 18VAC power supply to your AMX-100(FX) and to the AC socket.

NOTE: The power amplifier or powered monitors shall be turned ON after the AMX-100(FX) and OFF before the AMX-100(FX) is turned OFF.

4. Set the output level of your AMX-100(FX) or the connected power amplifier at no more than 75%.
5. Set the CONTROL ROOM / PHONE level at no more than 50%.
6. Set HI, MID and LOW EQ controls on center position.
7. Set panoramic (PAN / BAL) control on center position.
8. While speaking into the microphone (or playing the instrument) at normal volume, adjust the channel level control so that the input PEAK LED light-up only occasionally; in this way you will maintain good headroom and proper dynamic range.
9. You can shape the tone of each channel by adjusting the equalizer controls as desired.
10. Now repeat the same sequence for all input channels. The Main LED Meter could move up into the red section. In this case you can adjust the overall output level through the MAIN MIX control.

PREFADER AND POSTFADER CONSIDERATIONS

Interesting consideration! Where are the faders in your AMX-100(FX)?? Actually a fader is usually regarded as a slider; that is a linear potentiometer. All potentiometers in your AMX-100(FX) are of rotary type but we keep the prefader / postfader description that is quite industry standard and easily understandable.

When your AMX-100(FX) leaves the ▲LTO Factory the AUX bus of all input channels is wired postfader:

In this way, AUX bus can be used for the internal or external multieffect. If you want to use the AMX-100(FX) AUX bus for powered stage monitors, you should disconnect the above-indicated POST route track and solder the PRE route track like in this drawing.

In this way, the signal is routed to the AUX SENDS output before the Channel Level control.

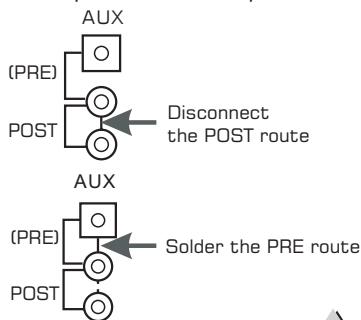

6. FOR THE EXPERTS WHO WANT TO KNOW MORE

As we have told you previously in this manual, the AUX SEND control both on mono and on stereo channels is factory wired as POST-FADER.

If you have some skill in electronic components soldering you can modify this setting and have all your AUX SENDS configured as PRE-FADER.

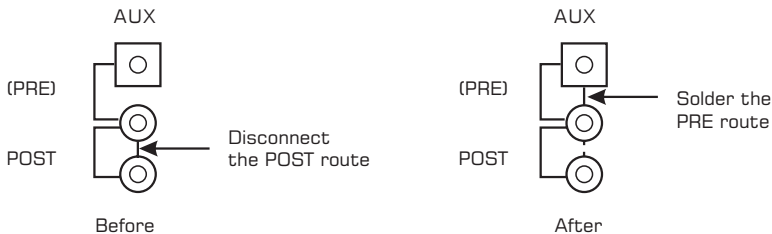

Modification on mono and stereo channels

7. PRESET LIST (For AMX-100FX Model)

NO. Preset	Description	Controllable parameter	
		Parameter	Variable range
1 VOCAL 1	Simulate a room with small delay time.	Decay time Pre-delay	0.8~1.1s 0~79ms
2 VOCAL 2	Simulate a small space with slight decay time.	Decay time Pre-delay	0.8~2.5s 0~79ms
3 LARGE HALL	Simulate a large acoustic space of the sound.	Decay time Pre-delay	3.6~5.4s 23~55ms
4 SMALL HALL	Simulate a small acoustic space of the sound.	Decay time Pre-delay	1.0~2.9s 20~45ms
5 LARGE ROOM	Simulate a studio room with many early reflections.	Decay time Pre-delay	2.9~4.5s 23~55ms
6 SMALL ROOM	Simulate a bright studio room.	Decay time Pre-delay	0.7~2.1s 20~45ms
7 PLATE	Simulate the transducers sound like classic bright vocal plate.	Decay time Pre-delay	0.6~6.1s 10ms
8 TAPE REVERB	Simulate a record head and multiple playback heads at intervals along the tape.	Decay time Pre-delay	1.3~5.4s 0~84ms
9 SPRING REVERB	Simulate the analog transducers' springs lightly stretched sound.	Decay time Pre-delay	1.3~5.4s 0~35ms
10 MONO DELAY	Reproduce the sound input on the output after a lapse of time.	Period	60~650ms
11 STEREO DELAY	Recreate the input sound on the stereo output with different time.	Period Feedback	210~400ms 37~73%
12 FLANGER	Simulate to play with another person carrying out same the notes on the same instrument	Rate	0.16~2.79Hz
13 CHORUS	Recreate the illusion of more than one instrument from a single instrument sound	Rate	0.5~5Hz
14 REV.+DELAY	Delay with room effect	Delay period Rev. decay time	211~375ms 1.0~2.9s
15 REV.+FLANGER	Stereo flanger and large room reverb	Flanger Rate Rev. decay time	0.16~2.52Hz 1.5~2.9s
16 REV.+CHORUS	Stereo chorus and large room reverb	Chorus rate Rev. decay time	0.5~4.74Hz 1.5~2.9s

8. BLOCK DIAGRAM

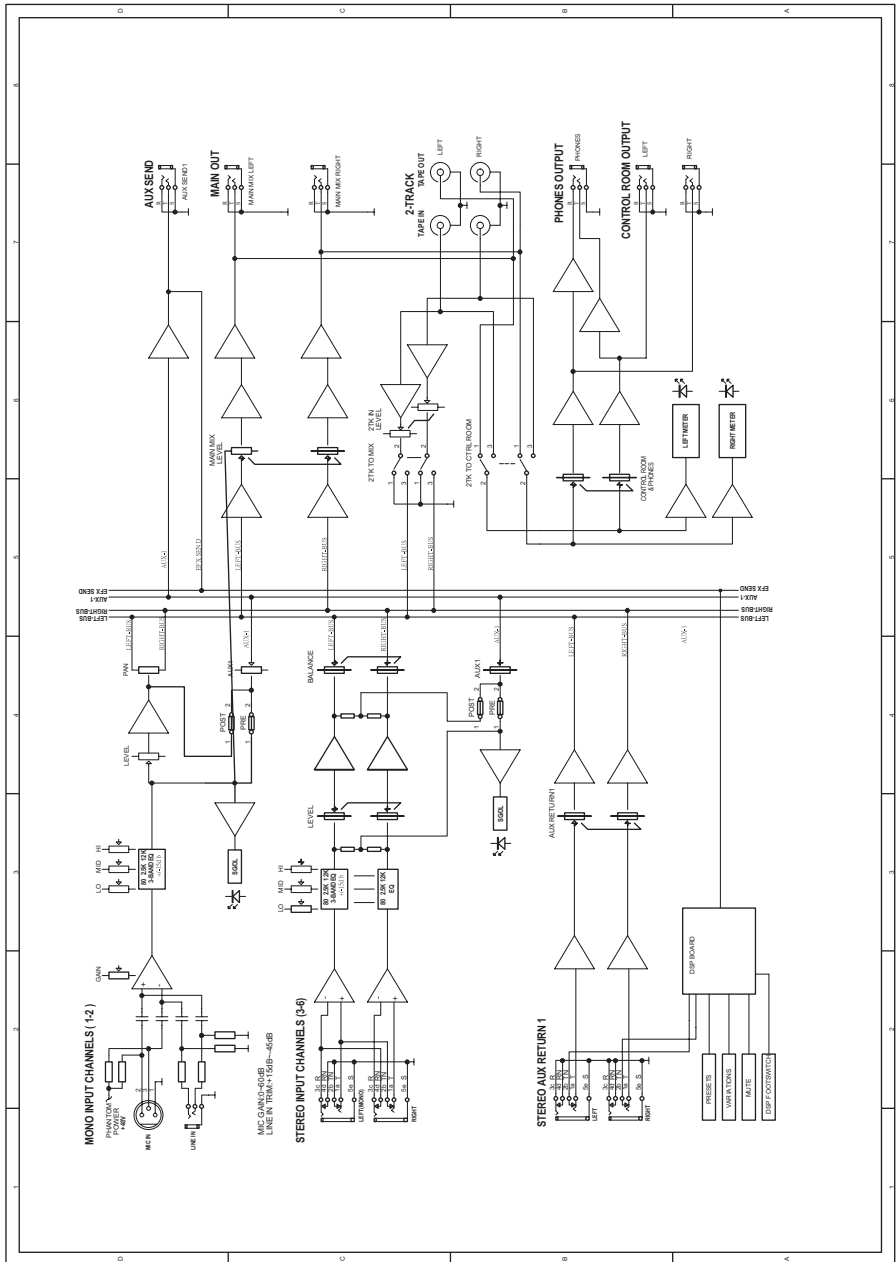

9. TECHNICAL SPECIFICATION

Mono input channels

Microphone input	Electronically balanced, discrete input configuration
Frequency response	10 Hz to 55 kHz, +/- 3 dB
Distortion (THD & N)	0.005% at +4 dBu, 1kHz
Gain range	0 dB to 44 dB (MIC)
SNR (Signal to Noise Ratio)	115 dB
Line input	electronically balanced
Frequency response	10 Hz to 55 kHz, +/- 3 dB
Distortion (THD & N)	0.005% at +4 dBu, 1 kHz
Sensitivity range	+15 dBu to -30 dBu

Stereo input channels

Line input	Balanced
Frequency response	10 Hz to 55 kHz, +/- 3 dB
Distortion (THD & N)	0.005% at +4 dBu, 1 kHz

Impedances

Microphone input	1.4k Ohm
All other inputs	10k Ohm or greater
Tape out	1k Ohm
All other output	120 Ohm

Equalization

Hi shelving	+/- 15 dB @12 kHz
Mid bell	+/- 12 dB @2.5 kHz
Low shelving	+/- 15 dB @80 Hz
Low Cut filter	75 Hz, 18 dB/oct.

DSP Section (For AMX-100FX Model)

A/D and D/A converters	24 bit
DSP resolution	24 bit
Type of effects	Hall, Room, Vocal & Plate REVERBS Mono & Stereo DELAY (max DELAY TIME 650ms) Chorus, Flanger & Reverb MODULATIONS REVERB+DELAY, REVERB+CHORUS, REVERB+FLANGER combinations
Presets	256
Controls	16-position PRESET Selector 16-position VARIATION selector PEAK LED MUTE SWITCH with LED indicator

Main Mix Section

Noise (Bus noise)	Fader 0 dB, channels muted:- 100 dB _r (ref.:+4 dBu) Fader 0 dB, all input channels assigned and set to UNITY gain: - 90 dB _r (ref.:+4 dBu)
Max output	+22 dBu unbalanced, 1/4" jacks
AUX Returns gain range	-∞ to +15 dB
AUX Sends max out	+22 dBu

10. WARRANTY

1. WARRANTY REGISTRATION CARD

To obtain Warranty Service, the buyer should first fill out and return the enclosed Warranty Registration Card within 10 days of the Purchase Date.

All the information presented in this Warranty Registration Card gives the manufacturer a better understanding of the sales status, so as to provide a more effective and efficient after-sales warranty service. Please fill out all the information carefully and genuinely, miswriting or absence of this card will void your warranty service.

2. RETURN NOTICE

- 2.1 In case of return for any warranty service, please make sure that the product is well packed in its original shipping carton, and it can protect your unit from any other extra damage.
- 2.2 Please provide a copy of your sales receipt or other proof of purchase with the returned machine, and give detail information about your return address and contact telephone number.
- 2.3 A brief description of the defect will be appreciated.
- 2.4 Please prepay all the costs involved in the return shipping, handling and insurance.

3. TERMS AND CONDITIONS

- 3.1 ▲LTO warrants that this product will be free from any defects in materials and/or workmanship for a period of 1 year from the purchase date if you have completed the Warranty Registration Card in time.
- 3.2 The warranty service is only available to the original consumer, who purchased this product directly from the retail dealer, and it can not be transferred.
- 3.3 During the warranty service, ▲LTO may repair or replace this product at its own option at no charge to you for parts or for labor in accordance with the right side of this limited warranty.
- 3.4 This warranty does not apply to the damages to this product that occurred as the following conditions:
 - Instead of operating in accordance with the user's manual thoroughly, any abuse or misuse of this product.
 - Normal tear and wear.
 - The product has been altered or modified in any way.
 - Damage which may have been caused either directly or indirectly by another product / force / etc.
 - Abnormal service or repairing by anyone other than the qualified personnel or technician.

And in such cases, all the expenses will be charged to the buyer:

- 3.5 In no event shall ▲LTO be liable for any incidental or consequential damages. Some states do not allow the exclusion or limitation of incidental or consequential damages, so the above exclusion or limitation may not apply to you.
- 3.6 This warranty gives you the specific rights, and these rights are compatible with the state laws, you may also have other statutory rights that may vary from state to state.

SEIKAKU TECHNICAL GROUP LIMITED
NO. 1, Lane 17, Sec. 2, Han Shi West Road, Taichung 40151, Taiwan
<http://www.altoproaudio.com> Tel: 886-4-22313737
email: alto@altoproaudio.com Fax: 886-4-22346757

All rights reserved to ALTO. All features and content might be changed without prior notice. Any photocopy, translation, or reproduction of part of this manual without written permission is forbidden. Copyright ©2007 Seikaku Group

NF01655-2.0